

Rapid, low-cost full-waveform mapping and analysis using ultrasonic phased arrays

David I A Lines
Diagnostic Sonar Ltd.
Livingston, West Lothian, EH54 7BX, UK
Tel: +44 (0)1506 411877
Fax: +44 (0)1506 412410
E-mail: dave.lines@diagnosticsonar.com

Robert A Smith, David Edgar, Jamie M Bending and Lyn D Jones
NDE Group, QinetiQ Ltd.
Farnborough, Hampshire, GU14 0LX, UK

Abstract

Many ultrasonic techniques have been proposed for large-area inspection of aircraft structures but few achieve the quality and versatility of information contained in the ultrasonic RF waveform. For example, spectral techniques applied to stored RF waveforms can measure hidden surface roughness to identify whether lap-joint thinning is due to corrosion⁽¹⁾. However inspection speed is always an issue.

Phased arrays can offer very rapid area coverage rates and Diagnostic Sonar and QinetiQ have reported early work with a large aperture high frequency array for lap-joint inspection⁽²⁾. The addition of piezo-composite array technology and of a coupling system optimized for high scan speeds have produced further significant improvements. A 124mm wide scan can be acquired at 4m/min with 1mm pixel resolution⁽³⁾.

The data acquisition and processing technology used for real-time B-scan imaging has now been incorporated into the ANDSCAN[®] mapping system which, with its Waveform Analysis plug-in, permits rapid full RF waveform capture over large areas with accurate absolute position of each waveform relative to the structure. Archiving, post-processing and analysis can now be done offline so minimizing aircraft downtime.

The paper reports on the improvements to the array and scanning system and outlines how the rapid acquisition of full waveform data can simplify the way that inspections are performed and ensure the future compatibility of the stored data.

1. Introduction

Aircraft include many safety critical components that require non-destructive testing (NDT) at manufacture and throughout the service life. There are many complementary approaches (e.g. visual inspection, radiography, eddy current) and each has its own advantages. However the ability to detect and quantify small mechanical defects at a range of depths within the structure has ensured that ultrasonic inspection techniques

have become widely used. Large area inspections are inherently time-consuming and the cost of both this and the associated downtime are considerable limitations. Some novel techniques (e.g. Lamb waves ⁽⁴⁾) have been developed to scan an area from a single probe placement so as to reduce the time and cost. However the high-resolution requirement precludes these for most aerospace applications and so pulse-echo inspection at each point on the surface of the structure remains the preferred technique.

It is necessary to generate a map of the acoustic measurements at each point on the surface to ensure 100% coverage and to document the inspection ⁽⁵⁾ but inspection time remains a problem. One approach is to speed up the conventional methods by using automated scanners and systems are available that scan either a single transducer in a raster scan or several single-element transducers simultaneously ⁽⁶⁾. An alternative is to electronically step a beam along a linear array of transducer elements and then scan this array over the surface ^(2, 3, 7-9).

These techniques are accelerated versions of conventional inspection of an area where the output is a map of the desired acoustic parameter, such as echo amplitude or time-of flight. However, the reduced inspection time is not the only benefit for the array systems because the very rapid acquisition allows interactive B-scanning that can greatly assist in the detection, localisation and characterisation of flaws ⁽⁹⁾.

All the above methods require the equipment to be correctly configured to derive the desired acoustic parameter at acquisition time. This requires a highly trained NDT inspector so that they can not only ensure that the system is optimally configured but also amend or extend the inspection in response to any indications found.

A solution is to acquire and store the full RF waveform. Many configuration parameters (e.g. gate range, delay and mode) can now be adjusted as part of the post-processing review and analysis process. Novel processing algorithms (e.g. spectral analysis ⁽¹⁾) can be tried out on archived data sets – a feature that ensures that new inspections remain “future-proof” against algorithm developments. The main disadvantages lie in the rapid acquisition rates needed and the amount of data to be stored. However recent developments in real-time imaging with arrays and with data storage make this approach practicable.

The paper reports on the development of such a system and outlines the changes to NDT inspection procedures that are likely to result from the use of this technique.

2. Full waveform acquisition with ultrasonic phased arrays

Ultrasonic phased arrays have now been in use for over 3 decades. The terminology has been adopted from phased array radar but this often leads to confusion and so it is helpful to clarify the different configurations in use for NDT.

2.1 Phased array configuration

Ultrasonic phased arrays were originally developed for medical cardiac imaging where the small array head size and the electronically steered beam were essential for

monitoring the rapid movements of the heart through the small access window between the ribs. Rapid improvements in image quality followed by using large aperture arrays, where the scanning is done by electronic stepping of a dynamically focused beam across the width of the array (see Figure 1), and this soon led to arrays being almost universally adopted for medical applications.

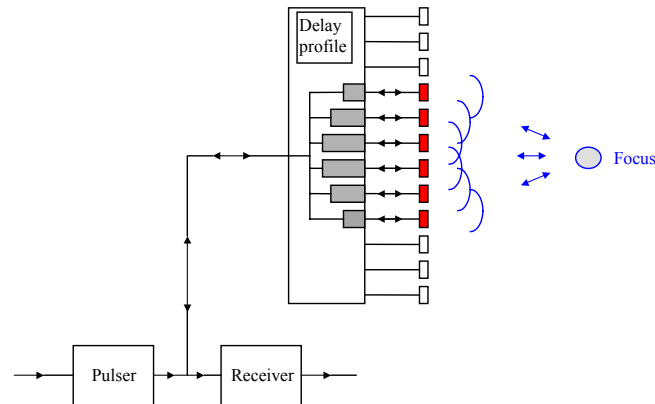

Figure 1. Step-scanned phased array. The beam is scanned by stepping the active aperture along the length of the array and the focus is altered by adjusting the delays in each channel to compensate for acoustic path differences.

It is now over 20 years since Diagnostic Sonar Ltd (DSL) modified one of their medical B-scanners with dynamic focus linear array so as to inspect carbon fibre composite (CFC) airframe structures. There have now been several generations of such equipment.

2.2 Advantages of arrays over automated scanners

The conventional approach to speeding up area inspections had been to resort to automated inspections⁽⁶⁾ but arrays offer several advantages:

- The array's electronic beam-forming ensures that echoes are in focus at all depths so increasing both resolution and sensitivity to small flaws.
- Array fabrication is a high precision process and so there is an inherent accuracy in any measurements made from the B-scan. In addition the overlapping beams ensures 100% coverage irrespective of mechanical backlash tolerances.
- Arrays produce many beams and so the mechanical translation speed is significantly lower than that of a mechanically scanned probe at the same area coverage rate. The coupling becomes more of a problem at high translation speeds and so the array is at a considerable advantage.
- The propagation time of the ultrasonic pulse is not insignificant at rapid translation rates and the probe is no longer in the same place to receive all the echoes. This not only reduces the sensitivity but also introduces a depth dependent positional error. A raster scan will show this as a backlash that is not easy to compensate since it is depth dependent. The zero-inertia of the array's electronic scan avoids this problem.
- The area coverage rate may ultimately be limited by the combination of material velocity and low attenuation. This requires an additional delay between pulses to

avoid confusion with echoes from earlier transmissions. Electronic scanning allows the beams to be fired in any sequence and interlaced fields can be used to operate with minimal delays. Indeed multiple simultaneous beam-forming is used in medical ultrasonic imaging to achieve the maximum scan rates.

- Arrays can be used to produce real-time images and this can greatly assist the operator to detect and characterise flaws when scanning freehand.

2.3 “Smart” arrays

The medical imaging market has continued to be the driving force behind many of the innovations in ultrasonic phased arrays, such as the adoption of piezo-composite array. However the wide diversity of NDT inspection requirements requires customized hardware and the cost of this, and of specialized operator training, means that arrays have had far less success in the NDT market.

A modular range of arrays and interface electronics has been developed by DSL to address this combined problem of cost and training. The nature of the application will define the number of elements in the array and whether focusing and steering is required. This in turn allows the selection of the appropriate type and number of standardised electronic modules for interfacing to the array. The use of generic modules ensures that the customisation needed for NDT applications can be done at minimum cost. All array controllers feature a common interface design that allows them to operate with a wide variety of equipment - from flaw detectors where the array automatically steps to the next beam on each transmission through to real-time imaging systems that can control all the scan and focus parameters^(8,9). The arrays can be small, low-cost and self-multiplexed to be used freehand or in existing scanning systems⁽⁷⁾ or large, high frequency and wide-band arrays suitable for spectral processing⁽¹⁻³⁾. All are suitable to act as the front-end of a full waveform acquisition system. Coupling is critical and special techniques have been developed to optimise this when scanning at speed⁽³⁾.

2.4 Full waveform acquisition

In current mapping systems, it is typical that only a single parameter is stored for each pixel on the 2 dimensional surface. The RF A-scan may well have many hundreds of samples and so the full waveform system will need an increase in data acquisition rates and storage of 2 to 3 orders of magnitude. This massive increase requires a different technology but fortunately these requirements are the same as for real-time B-scanning – the only difference being that the data is retained in memory rather than just being directed to the display.

The background to the ultrasonic image acquisition and processing system has been reported elsewhere⁽⁹⁾ and the frame rate of the current version is constrained only by the acoustic velocity and attenuation of the target material.

2.5 Full waveform analysis

The availability of the full RF waveform at analysis permits many new operations:

- Spectral filtering (linear and non-linear) is possible both before and after any rectification operation;
- There is no limit on the number of gates and each can be configured to operate on either (or both) signal polarity;
- Gates can be referenced to other gates making it easy to construct interface-following gates and even pre-triggering;
- Arbitrary combinations of results from multiple gates are possible (e.g. the ratio of an echo in one gate divided by the amplitude of the front interface echo in another gate provides an automatic normalisation of echoes when the interface is not flat);
- Ultrasonic spectroscopy can be performed over multiple gates so as to implement roughness measurement for corrosion assessment⁽¹⁾.

The Waveform Analysis plug-in to the ANDSCAN[®] mapping system has been developed to perform these operations.

2.6 Implications on inspection procedures

The ability to manipulate many more parameters at analysis means that the inspection set-up is less critical and could allow the use of a less-qualified inspector. However, it is essential that the data acquired is of high quality and so the dynamic range and the acquisition window must encompass the full range of echoes of interest. In addition, any signal filters must not exclude any frequencies to be analysed later and the digitizer sampling rate and resolution must be adequate to reconstruct the signal accurately.

Quality acoustic coupling must be maintained over the whole area inspected and so some form of monitoring is essential. Experience has shown that a C-scan, derived from gated data that would flag-up a coupling fault, should be used during the scan to monitor the inspection process and to immediate indication of any potential flaws.

The inspection procedure should include documentation of any reference and calibration points (both positional and acoustic). It is also recommended that a quick review is made of the stored data before leaving the inspection site to ensure that retrieval is possible and indeed standard backup procedures should be followed.

The reduction in inspection time maximises aircraft availability but is balanced by an increase in analysis time though this could be performed by a different operator with appropriate experience.

3. Conclusions

It has been shown that there are many advantages in acquiring the full RF waveform for each surface point in an area scanning system. Multiple gate inspections are quicker and all data acquired is available for full offline analysis and so is “future-proof” against algorithm developments. The implications on the inspection procedure, including the possibility of using a less-qualified operator to perform the inspection, are discussed.

The massive increase in data rates would normally slow down the inspection but DSL's FlawInspecta technology, developed for real-time B-scanning with ultrasonic arrays has been adapted to maintain rapid inspection speeds at low cost. It has been incorporated into the ANDSCAN[®] mapping system with Waveform Analysis plug-in so that this capability is now commercially available.

Acknowledgements

The work was funded by the Ministry of Defence through the Structures Support Group.

References

1. R A Smith and D A Bruce, 'An ultrasonic spectroscopy method for measuring the roughness of hidden corrosion surface', Proceedings of NDT'98, The British Institute of NDT (ISBN 0 903132 26 5), pp 167-170, 1998.
2. D I A Lines, K R Dickinson, R A Smith and S J Willsher, 'Optimization of High-Frequency Array Technology for Lap-joint Inspection', Proceedings of the 3rd Joint DoD/FAA/NASA Conference on Aging Aircraft, Albuquerque, 1999.
3. R A Smith, J M Bending, L D Jones, T R C Jarman TRC and D I A Lines, 'Rapid Ultrasonic Inspection of Ageing Aircraft', INSIGHT, Vol 45, No 3, pp 174-177, 2003.
4. P Cawley, 'Practical long range guide wave inspection – applications to pipes and rail', Proceedings of NDE2002,, Chennai, India, 5-7 December 2002, <http://www.nde2002.org/papers/045P.pdf>
5. R A Smith and L D Jones, 'Evaluation and accuracy assessment of ANDSCAN – a non-destructive portable scanner', INSIGHT - Journal of the British Institute of NDT, Vol 37, No 4, pp 284-289 and Vol 37, No 5, pp 352-357, 1995.
6. M K Reighard, T W Van Oordt and N L Wood, 'Rapid ultrasonic scanning of aircraft structures', Materials Evaluation, Vol 49, No 12, pp 1506-1514, 1991.
7. S J Willsher and R A Smith, 'Multi-element ultrasonic scanning of in-service airframes', INSIGHT, Vol 40, No 3, pp 154-159, 1998.
8. D I A Lines, 'Rapid inspection using integrated ultrasonic arrays', INSIGHT, Vol 40, No 8, pp 573-577, 1998.
9. D I A Lines, K R Dickson, G Filippi and T Moir, 'A real-time image acquisition and processing system for ultrasonic arrays in NDT', Proceedings of NDT'99, The British Institute of NDT (ISBN 0 903132 27 3), pp.11-17, 1999.

© Copyright Diagnostic Sonar and QinetiQ Ltd, 2003. Published with the permission of QinetiQ Ltd.

ANDSCAN is a Registered Trademark of QinetiQ Ltd.